

SGL-C DISK/CLAMP TYPE//LONGER FLEXIBLE COUPLING

Features :

- Suitable for servo-motor and precision transmission mechanism.
- double disks , low moment of inertia and zero backlash.
- Allow minor deviation in eccentricity , angularity and end -play.
- Fixed method: Clamp type. Material: Aluminum alloy.

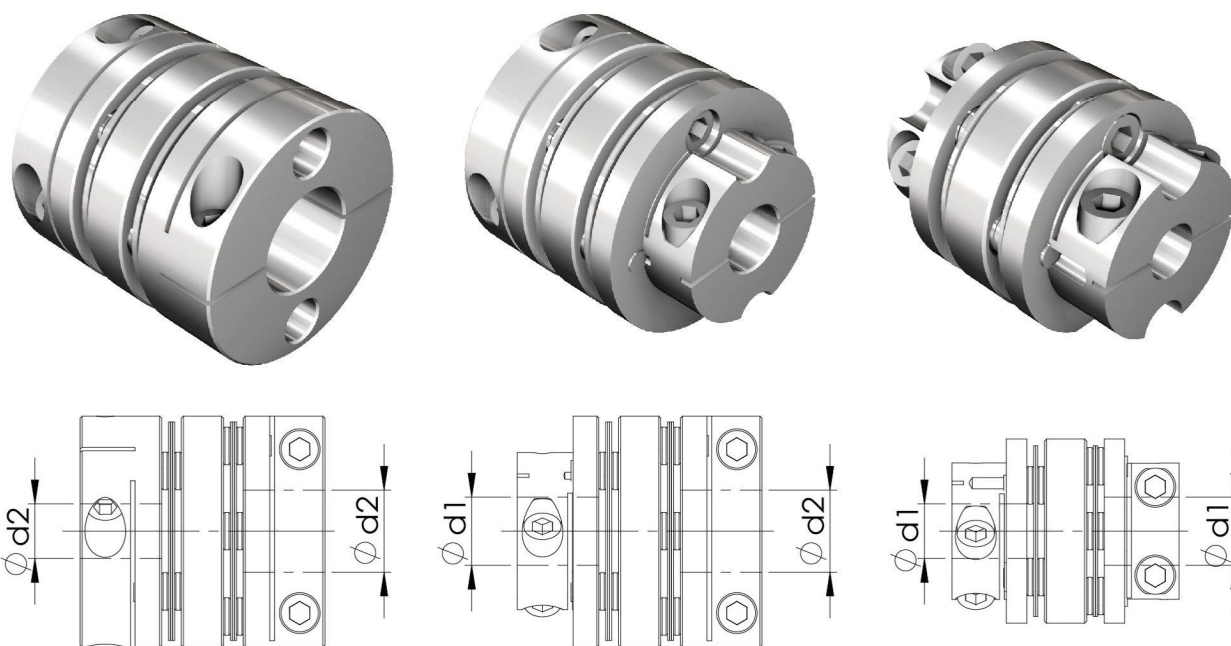

Model No.	ϕ d1	ϕ d2
Figure.		
SGL27C	4 ~ 6.35	7 ~ 10
SGL34C	6 ~ 9.525	10 ~ 14
SGL40C	8 ~ 10	11 ~ 16
SGL45C	10 ~ 13	14 ~ 19
SGL50C	10 ~ 16	17 ~ 22
SGL57C	12 ~ 18	19 ~ 24
SGL65C	12 ~ 21	22 ~ 28

SGL-C DISK/CLAMP TYPE//LONGER FLEXIBLE COUPLING

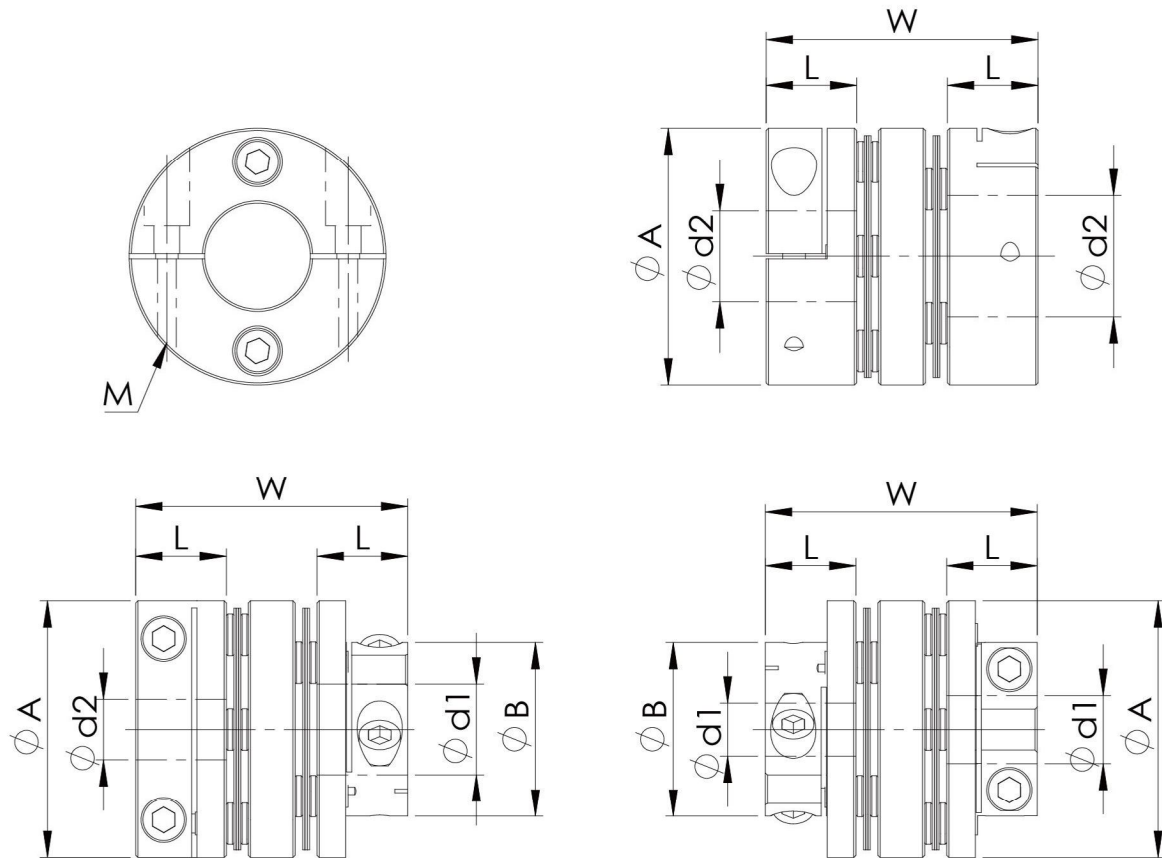

Dimension

Catalog Number	ϕA	ϕB	L	W	$\phi d1 \times \phi d2$		Setscrew Max. torque.	
					Stock bores. (H8)		M	kgf-cm
					$\phi d1$	$\phi d2$		
SGL-27C	27	20	11	33.5	4 ~ 6.35	7 ~ 10	4 - M3	20
SGL-34C	34	23	12	36	6 ~ 9.525	10 ~ 14	4 - M3	20
SGL-40C	40	27	15	46	8 ~ 10	11 ~ 16	4 - M4	35
SGL-45C	45	34	15	46	10 ~ 13	14 ~ 19	4 - M4	35
SGL-50C	50	40	20	59	10 ~ 16	17 ~ 22	4 - M5	75
SGL-57C	57	45	20	59	12 ~ 18	19 ~ 24	4 - M5	75
SGL-65C	65	50	24	71	12 ~ 21	22 ~ 28	4 - M6	100

Specifications

Catalog Number	Rated Torque (N . m)	Max Torque (N . m)	Max Rotational Frequency (min-1)	Moment of Inertia (Kg.m ²)	Errors of Eccentricity (mm)	Errors of Angularity (°)	Errors of Shaft End-Play (mm)	Weight (g)
SGL-27C	2	4	10000	4.7×10^{-6}	0.15	2°	±0.33	-
SGL-34C	5	10		1.4×10^{-5}	0.17		±0.4	-
SGL-40C	7	14		3.1×10^{-5}	0.22		±0.5	-
SGL-45C	10	20		4.8×10^{-5}	0.22		±0.6	-
SGL-50C	16	32		9.8×10^{-5}	0.24		±0.7	-
SGL-57C	26	52		16.2×10^{-5}	0.27		±0.8	-
SGL-65C	60	120		40×10^{-5}	0.35		±0.9	-