

JWTS® MEGAlife

MEGAlife maintenance-free roller and conveyor chains can be applied in all areas where post installation lubrication is not at all or only partly possible. This is the case in clean and dry surroundings or in applications with difficult lubrication passage. MEGAlife maintenance-free chains are corrosion resistant due to nickel-plated parts and can be utilized in a temperature range from $-40\text{ }^{\circ}\text{C}$ up to $+150\text{ }^{\circ}\text{C}$. The chains are supplied either dry or with special-purpose lubrication in line with the requirements of the applied application.







iwis® MEGAlife I and MEGAlife II

The maintenance-free iwis chains for new conveyor technology

MORE ADDED VALUE



STARTING POINT

MEGAlife maintenance-free roller chains and conveyor chains can be used in all applications where relubrication is impossible or impractical.

OUR SOLUTION

MEGAlife maintenance-free roller and conveyor chains offer a **significantly longer service life than conventional low-maintenance/lube-free roller chains.**

The benefits for you:

- Less downtime
- Longer replacement intervals for machine and system components
- Significant reduction of maintenance costs

HIGHLIGHTS MEGALIFE I

- **Excellently qualified for normal chain applications without relubrication at speeds amounting to max. 3 m/s**
- Permanently maintenance-free under certain conditions
- Easy to dismantle due to easy break
- Applicable in corrosive environments; recommendable with lubrication, if possible
- 100 % compatibility with iwis standard conveyor chains due to the use of original iwis attachments
- MEGAlife conveyor chains with elongated pins are chemically nickel-plated
- All roller chains are mounted with shouldered pins
- Also available as transfer chain TF, power and free conveyor chain SF or grip chain

HIGHLIGHTS MEGALIFE II

- **The solution for fast running chain drives, $v > 3$ m/s and/or high loads**
- Considerably improved wear resistance due to a special thermo-chemical treatment of the pins which influences the hardness of the surface and optimizes herewith the adhesiveness
- Distinctive longer lifetime
- Pins and sintering bushes are optimally adjusted to each other
- Not recommendable in environments susceptible to corrosion
- Mainly applied as drive chain
- For demanding applications

MORE QUALITY

- 1 Seamless sintered bush made of a material specially developed for this application, hardened and treated to optimize its tribological properties
- 2 Pin with wear-resistant, friction-optimized coating
- 3 Seamless roller with corrosion-resistant coating and geometry optimized on the sinter bush

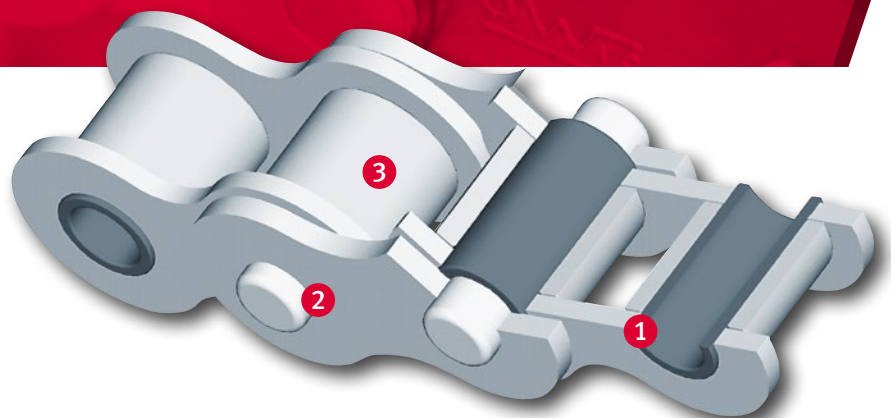



MEGAlife is the benchmark **for extremely high fatigue strength and breaking resistance**, with a proven track record in many practical applications.

CUSTOMER BENEFITS

- Extremely high levels of fatigue and breaking strength
- Excellent wear resistance – even at high speeds and loads – where conventional maintenance-free chains stretch
- Protected from corrosion due to nickel-plated parts
- Temperature range from -40 °C up to +150 °C
- It's easy to convert standard chain and conveyor chain applications to MEGAlife: since construction of these chain types follows a modular principle, they are interchangeable and mutually compatible – **no special adaptation required!**
- MEGALIFE chains are clean, dry and environmentally-friendly due to absence of excess lubrication

AREAS OF APPLICATION

- Packaging and food industry
- Printing industry
- Material handling, conveyor systems
- Textile and clothing industry
- Paper manufacture and book binding industry
- Electronics industry and PCB manufacture
- Wood, glass and ceramics Industry
- Medical technology
- Lamp and lightbulb manufacture

... and of course in all areas where relubrication is not at all or only partly possible.

PRODUCT RANGE

- Roller chains according to ISO 606
- Roller chains with different attachments
- Roller chains with straight side plates
- Accumulation chains
- Transfer chains
- Grip chains
- Special conveyor chains

... almost the entire JWIS chain range can be manufactured in the maintenance-free ML version. Contact us for more details!

MORE EFFICIENCY

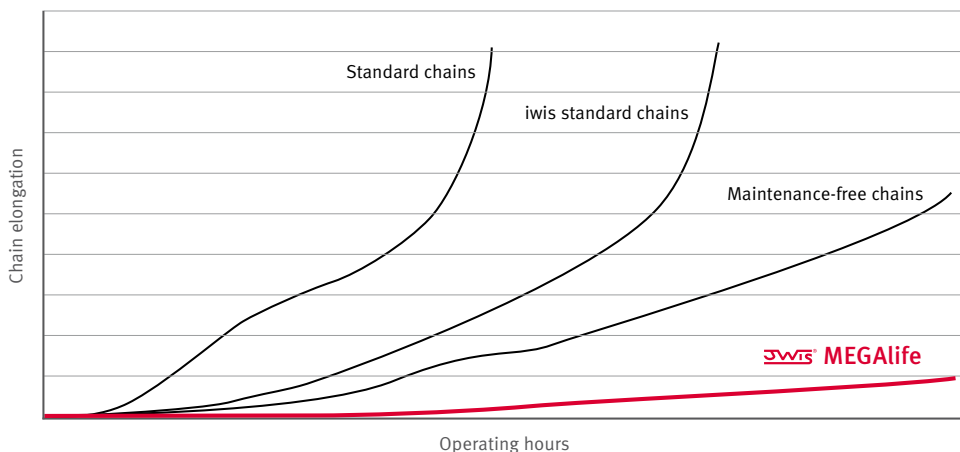



iwis® MEGAlife I – Roller Chains

based on iwis roller chains complying with ISO 606

ISO	iwis reference	Pitch p (°)	Pitch p (mm)	Ave. tensile strength F_a (N)	Min. tensile strength F_u (N)	Breaking area f (cm ²)	Weight per m q (kg/m)	b_1 (mm) min.	b_2 (mm) min.	g (mm) max.	Inner link			Outer link			Article No.
											a_1 (mm) max. ¹⁾	a (mm) max. ¹⁾	Roller d_1 (mm) max.	Pin d_2 (mm) max.	Transverse pitch e (mm)		
Simplex																	
06 B-1	G 67 ML*	3/8	9.525	11,000	8,900	0.28	0.41	5.72	8.53	8.20	12.90	14.10	6.35	3.31	–	50033917	
08 B-1	L 85 ML	1/2	12.70	22,000	17,800	0.50	0.70	7.75	11.30	11.80	16.90	18.50	8.51	4.45	–	50026256	
08 A-1 ANSI 40	L 85 AML	1/2	12.70	17,500	13,900	0.44	0.60	7.94	11.15	12.00	16.60	17.50	7.95	3.96	–	50036841	
10 B-1	M 106 ML	5/8	15.875	25,000	22,200	0.67	0.95	9.65	13.28	14.40	19.50	20.90	10.16	5.08	–	50026257	
12 B-1	M 127 ML	3/4	19.05	30,000	28,900	0.89	1.25	11.75	15.62	16.20	22.70	23.60	12.07	5.72	–	50026258	
12 A-1 ANSI 60	M 128 AML	3/4	19.05	41,000	31,300	1.06	1.47	12.70	17.75	18.00	25.30	26.70	11.91	5.96	–	50038464	
16 B-1	M 1611 ML	1	25.4	75,000	60,000	2.10	2.70	17.02	25.45	21.10	36.10	36.90	15.88	8.28	–	50028923	
20 B-1	M 2012 ML	1 1/4	31.75	120,000	95,000	2.92	3.72	19.56	29.1	26.2	41.6	43.3	19.05	10.17	–	50037775	
Duplex																	
06 B-2	D 67 ML	3/8	9.525	19,000	16,900	0.56	0.78	5.72	8.53	8.20	23.40	24.60	6.35	3.31	10.24	50033832	
08 B-2	D 85 ML	1/2	12.70	40,000	31,100	1.00	1.35	7.75	11.30	11.80	30.80	32.40	8.51	4.45	13.92	50027439	
10 B-2	D 106 ML	5/8	15.875	50,000	44,500	1.34	1.85	9.65	13.28	14.40	36.00	37.50	10.16	5.08	16.59	50027509	
12 B-2	D 127 ML	3/4	19.05	60,000	57,800	1.78	2.50	11.75	15.62	16.40	42.10	43.00	12.07	5.72	19.46	50027457	
16 B-2	D 1611 ML	1	25.40	150,000	106,000	4.21	5.40	17.02	29.45	21.10	68.00	68.80	15.85	8.28	31.88	50033161	
20 B-2	D 2012 ML	1 1/4	31.75	210,000	170,000	5.84	7.36	19.56	29.01	25.40	79.70	82.90	19.05	10.19	36.45	50033771	
Triplex																	
08 B-3	TR 85 ML	1/2	12.70	58,000	44,500	1.50	2.00	7.75	11.30	11.80	44.70	46.30	8.51	4.45	13.92	50027510	
10 B-3	TR 106 ML	5/8	15.875	75,000	66,700	2.02	2.80	9.65	13.28	14.40	52.50	54.00	10.16	5.08	16.59	50027511	
12 B-3	TR 127 ML	3/4	19.05	89,000	86,700	2.68	3.80	11.75	15.62	16.40	61.50	62.50	12.07	5.72	19.46	50027512	
16 B-3	TR 1611 ML	1	25.40	219,000	160,000	6.32	8.00	17.02	25.45	21.10	99.20	100.70	15.88	8.28	31.88	50033628	

* Also available in 10 m length (Art. 50035181), with straight side plates ¹⁾ Differing dimensions for cranked links
If cranked links are fitted, it should be noted that the breaking strength of the chain may be reduced by approximately 20 %.

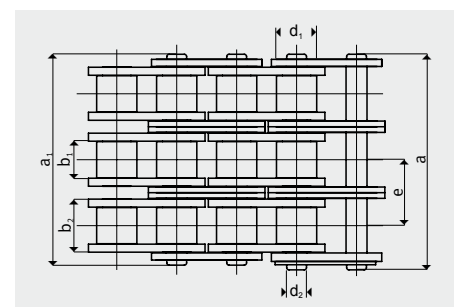
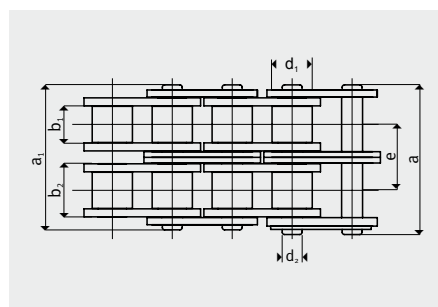
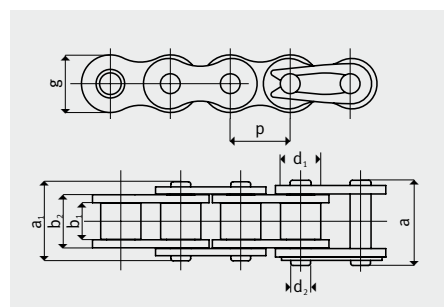



iwis® MEGAlife I – Conveyor Chains with straight attachment plates

based on iwis roller chains complying with ISO 606

ISO	iwis reference	Pitch p (°)	Pitch p (mm)	Ave. tensile strength F_a (N)	Min. tensile strength F_u (N)	Breaking area f (cm ²)	Weight per m q (kg/m)	b_1 (mm) min.	Inner link b_2 (mm) min.	g (mm) max.	Outer link a_1 (mm) max. ¹⁾	a (mm) max. ¹⁾	Roller d_1 (mm) max.	Pin d_2 (mm) max.	Transverse pitch e (mm)	Article No.
Simplex/Duplex – MEGAlife roller chains with straight side plates																
08B-1	L 85 ML-GL	1/2	12.7	–	17,800	0.5	0.7	7.75	11.3	12.2	16.9	18.5	8.51	4.45	–	50049011
08B-2	D 85 ML-GL	1/2	12.7	–	31,100	1	1.35	7.75	11.3	12.2	30.8	32.4	8.51	4.45	13.92	50046481
10 B-1	M 106 ML-GL	5/8	15.875	24,000	22,200	0.67	0.95	9.65	13.28	13.90	19.50	20.90	10.16	5.08	–	50035304
10 B-2	D 106 ML-GL	5/8	15.875	47,500	44,500	1.34	1.85	9.65	13.28	13.90	36.00	37.50	10.16	5.08	16.59	50034083
12 B-1	M 127 ML-GL	3/4	19.05	30,000	28,900	0.89	1.30	11.75	15.62	16.10	22.70	23.60	12.07	5.72	–	50037351
12 B-2	D 127 ML-GL	3/4	19.05	63,000	57,800	1.78	2.50	11.75	15.62	16.10	42.10	43.00	12.07	5.72	19.46	50034084
16B-1	M 1611 ML-G	1	25.4	77,000	60,000	2.1	2.7	17.02	25.45	20.65	36.1	36.9	15.88	8.28	–	50048583
16B-2	D 1611 ML-GL	1	25.4	151,000	106,000	4.21	5.4	17.02	25.45	20.65	68	68.8	15.88	8.28	31.88	50048584

¹⁾ Differing dimensions for cranked links If cranked links are fitted, it should be noted that the breaking strength of the chain may be reduced by approximately 20 %.

HIGHLIGHTS

- Optimum solution for conveyors and transport systems
- Compared to competition products, MEGAlife chains maintain significantly higher rigidity and less wear elongation during their entire service life
- Extremely high availability of conveyor systems, as the customary shutdowns for regular maintenance are no longer necessary
- Guaranteed long service life and cleanliness of conveyor systems in the automotive, logistics and other maintenance-free industries

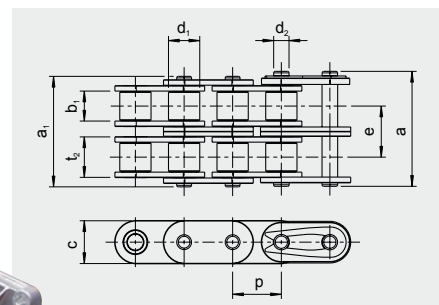
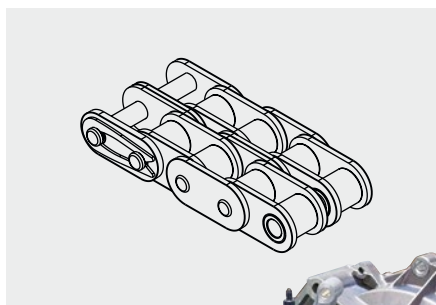
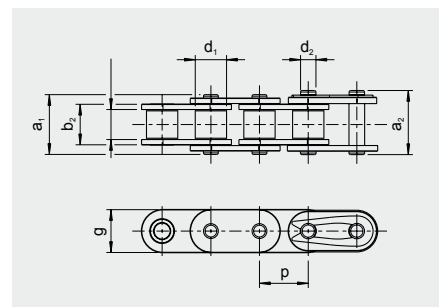
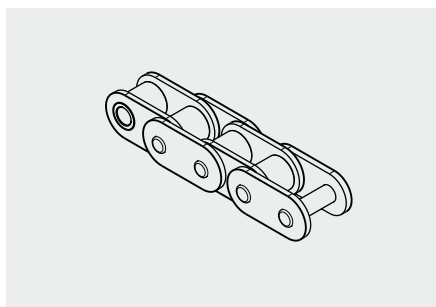



iwis® MEGAlife I – Conveyor Chains with straight attachment plates based on iwis roller chains complying with ISO 606

ISO	iwis reference	Pitch ²⁾		a (mm)	b (mm)	d (mm)	Simplex chains e ₁ (mm)	Duplex chains e ₂ (mm)	Triplex chains e ₃ (mm)	g (mm)	i (mm)	l (mm)	s (mm)	M (mm)	Threaded insert m max. (mm)
		p (°)	p (mm)												
Plate No. 102.1															
08 B-1	L 85 ML ¹⁾	1/2	12.70	13.0	19.0	4.2	11.6	25.5	39.4	5.4	–	18.0	1.5	4	5.2
10 B-1	M 106 ML ¹⁾	5/8	15.875	16.3	24.3	5.2	13.6	30.1	46.6	6.8	–	24.0	1.6	5	5.3
12 B-1	M 127 ML ¹⁾	3/4	19.05	19.1	29.1	6.2	15.9	35.3	54.7	7.4	–	28.0	1.8	5	5.5
16 B-1	M 1611 ML	1	25.40	24.6	36.6	8.2	25.9	57.8	89.7	10.4	–	36.2	3.0	6	8.2
Plate No. 103.1 and 103.2															
08 B-1	L 85 ML ¹⁾	1/2	12.70	17.0	23.0	4.2	11.6	25.5	39.4	5.4	12.7	23.6	1.5	4	5.2
10 B-1	M 106 ML ¹⁾	5/8	15.875	16.3	25.8	5.2	13.6	30.1	46.6	7.5	15.8	31.0	1.6	5	5.3
12 B-1	M 127 ML ¹⁾	3/4	19.05	18.3	29.0	6.2	15.9	35.3	54.7	9.0	19.0	37.2	1.8	5	5.5
16 B-1	M 1611 ML	1	25.40	28.45	41.55	8.2	25.9	57.8	89.7	10.35	25.4	47.2	3.0	6	8.2

¹⁾ Also for the corresponding duplex and triplex chains ²⁾ Nominal pitch

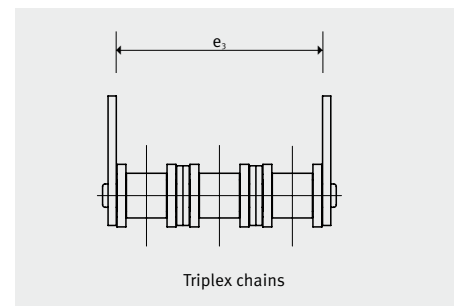
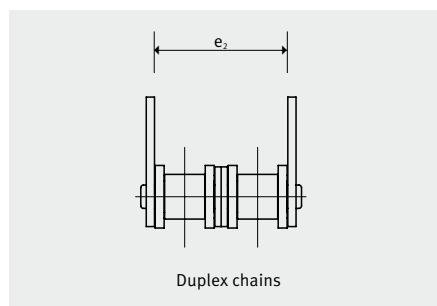
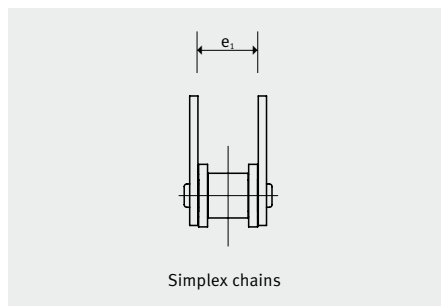

STRAIGHT ATTACHMENT PLATES

The versions shown are also available as snap-on and outer links for final assembly and repair.

Straight attachments can be fitted on one or both sides of every outer link or at longer intervals.

Additional conveyor chains and threaded inserts on request.

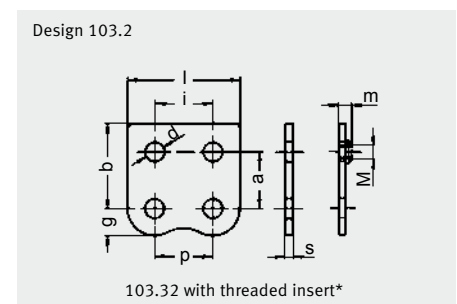
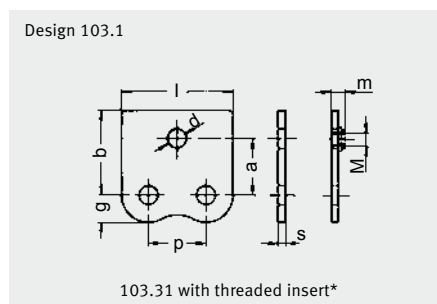
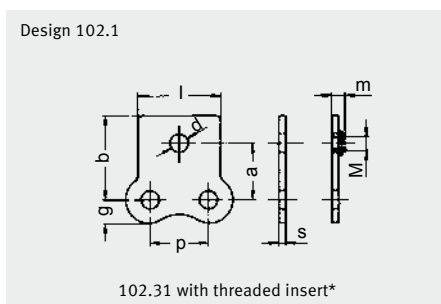

* Available on request.



iwis® MEGAlife I – Conveyor Chains with bent attachment plates based on iwis roller chains complying with ISO 606

ISO	iwis reference	Pitch ³⁾			Simplex chains			Duplex chains			Triplex chains			Threaded insert					
		p (°)	p (mm)	c (mm)	d (mm)	e ₁ (mm)	f ₁ (mm)	e ₂ (mm)	f ₂ (mm)	e ₃ (mm)	f ₃ (mm)	g (mm)	h (mm)	i (mm)	l (mm)	s (mm)	M (mm)	m max. (mm)	
Plate No. 202.1																			
08 B-1	L 85 ML ¹⁾	1/2	12.70	8.0	4.2	27.6	39.6	41.5	53.5	55.4	67.4	5.4	14.0	-	18.1	1.5	4	5.2	
10 B-1	M 106 ML ¹⁾	5/8	15.875	9.0	5.2	33.6	49.6	50.1	66.1	66.6	82.6	6.8	18.0	-	24.0	1.6	5	5.3	
12 B-1	M 127 ML ¹⁾	3/4	19.05	10.0	6.2	41.1	61.1	60.5	80.5	79.9	99.9	7.4	22.6	-	28.0	1.8	5	5.5	
16 B-1	M 1611 ML	1	25.40	16.0	8.2	53.9	77.9	85.8	109.8	117.7	141.7	10.4	26.0	-	36.2	3.0	6	8.2	
Plate No. 203.1 and 203.2																			
08 B-1	L 85 ML ^{1) 2)}	1/2	12.70	9.5	4.2	32.6	44.6	46.5	58.5	60.4	72.4	5.4	16.5	12.7	23.6	1.5	4	5.2	
10 B-1	M 106 ML ^{1) 2)}	5/8	15.875	11.0	5.2	30.6	49.6	47.1	66.1	63.6	82.6	7.5	18.0	15.8	31.0	1.6	5	5.3	
12 B-1	M 127 ML ^{1) 2)}	3/4	19.05	12.0	6.2	35.5	56.9	54.9	76.3	74.3	95.7	9.0	20.5	19.0	37.2	1.8	5	5.5	
16 B-1	M 1611 ML	1	25.40	18.0	8.2	57.7	83.9	89.6	115.8	121.5	147.8	10.4	29.0	25.4	47.2	3.0	6	8.2	

Conveyor chains D 1611 ML and TR 1611 ML on request ¹⁾ Also for corresponding duplex and triplex chains ²⁾ Assembly of bent attachments also possible inward over the chain except when fitted on both sides to D 85 ML, D 106 ML and D 127 ML ³⁾ Nominal pitch

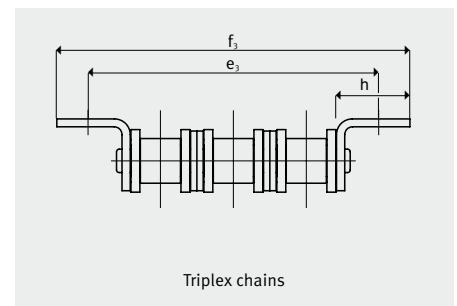
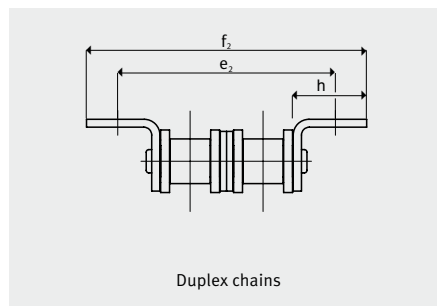
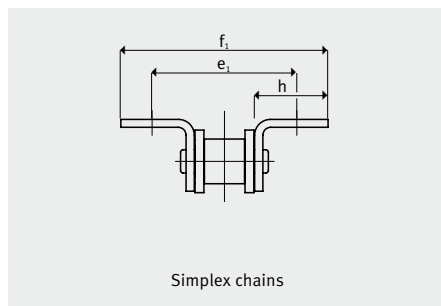

BENT ATTACHMENTS

The types illustrated are also obtainable for connector and outer link for final assembly and repair. Assembly of the bent attach-

ments with threaded insert over the chain facing inwards is not possible. Fitting bent attachments on one or both sides on each

outer link or at greater spacing is possible. Other conveying chains and threaded inserts on request.

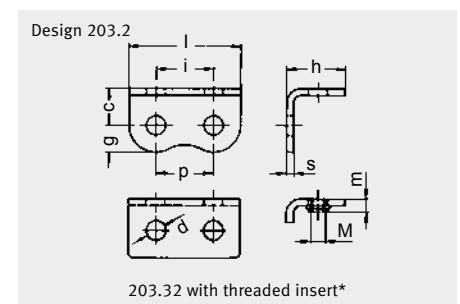
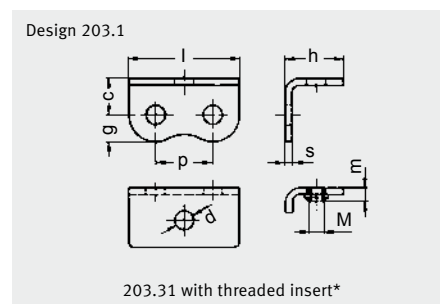
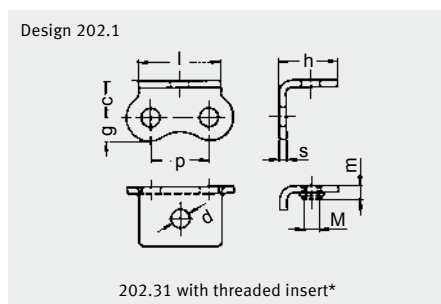

* Available on request.



iwis® MEGAlife I – Conveyor Chains with extended pins

based on iwis chains complying with ISO 606

ISO	iwis reference ¹⁾	P (°)	Pitch ²⁾		Inner width b ₁ (mm)	Roller Ø d ₁ (mm)	Pin Ø d ₂ (mm)	L ₁ (mm)	Design A		Design B and C	
			P (mm)						l ₁ (mm)	L ₂ (mm)	l ₂ (mm)	l ₃ (mm)
Pin design A, B, C												
08 B-1	L 85 ML ¹⁾	1/2	12.7	7.75	8.51	4.45	25.5	10.0	40.5	25.0	13.0	
10 B-1	M 106 ML ¹⁾	5/8	15.875	9.65	10.16	5.08	30.0	12.0	48.0	30.0	15.5	
12 B-1	M 127 ML ¹⁾	3/4	19.05	11.75	12.07	5.72	36.0	15.0	51.0	30.0	15.5	
16 B-1	M 1611 ML	1	25.4	17.02	15.88	8.28	53.8	20.0	68.5	35.0	18.0	

¹⁾ For multiple chains on request. ²⁾ Nominal pitch. Other pin lengths and shapes on request.

EXTENDED PINS

The types illustrated are also available as connecting links and outer links for final assembly and repair (C only as outer link).

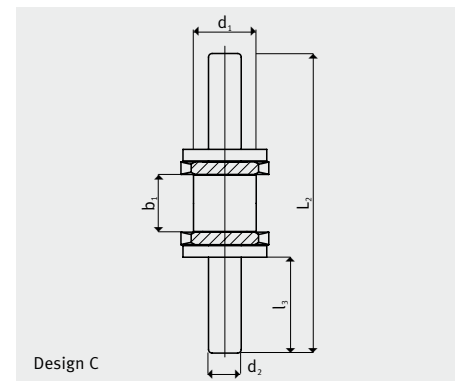
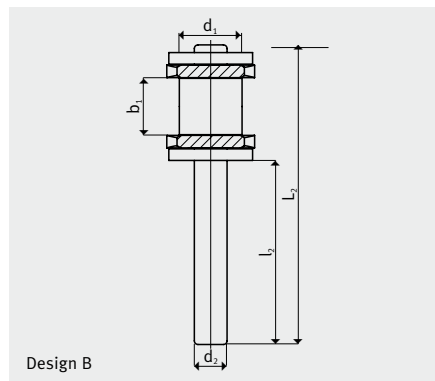
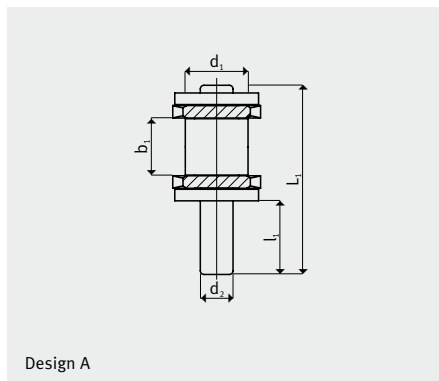

iwis® MEGAlife I – Transfer Chains

based on iwis roller chains complying with ISO 606

iwis reference	B ₁	b	h	H ₁	Article No. (5 m)
L 85 TF ML-1	20	7.5	3.1	15.4	50027317
M 106 TF ML-1	25	9.5	3.1	17.7	50036409
M 127 TF ML-1	30	11.3	2.9	20.0	50032663

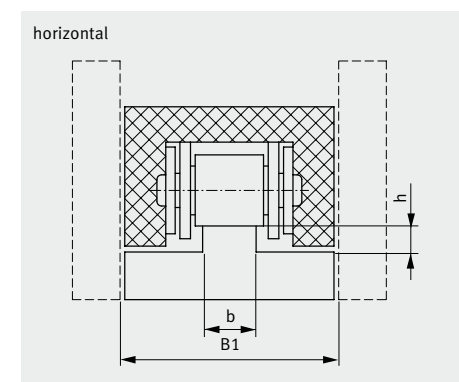
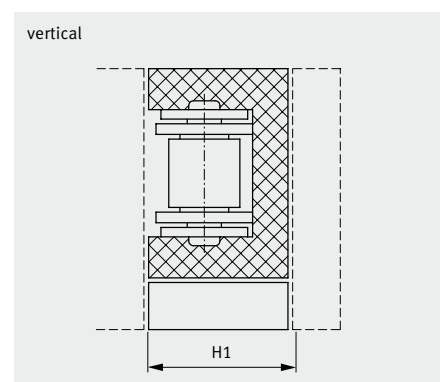



MEGALife II – Roller Chains

according to ISO 606

ISO	iwis reference	Pitch p (")	Pitch p (mm)	Ave. tensile strength F_a (N)	Min. tensile strength F_u (N)	Bearing area F (cm ²)	Weight per m q (kg/m)	b_1 (mm) min.	b_2 (mm) min.	g (mm) max.	Inner link	Outer link	5 m versions			Article No.
											a_1 (mm) max. ¹⁾	a (mm) max. ¹⁾	Roller d_1 (mm) max.	Pin d_2 (mm) max.	Transverse pitch e (mm)	
Simplex																
06 B-1	G 67 ML-2*	3/8	9.525	11,000	8,900	0.28	0.41	5.72	8.53	8.20	12.90	14.10	6.35	3.31	-	50030791
08 B-1	L 85 ML-2	1/2	12.70	22,000	17,800	0.50	0.70	7.75	11.30	12.20	16.90	18.50	8.51	4.45	-	50030461
10 B-1	M 106 ML-2	5/8	15.875	25,000	22,200	0.67	0.95	9.65	13.28	14.40	19.50	20.90	10.16	5.08	-	50030462
12 B-1	M 127 ML-2	3/4	19.05	30,000	28,900	0.89	1.25	11.75	15.62	16.40	22.70	23.60	12.07	5.72	-	50030463
16 B-1	M 1611 ML-2	1	25.40	75,000	60,000	2.10	2.72	17.02	25.45	21.10	36.10	36.90	15.88	8.28	-	50030464
20 B-1	M 2012 ML-2	1 1/4	31.75	120,000	95,000	5.84	3.72	19.56	29.10	26.60	77.00	79.70	19.05	10.17	36.45	50033036
Duplex																
06 B-2	D 67 ML-2	3/8	9.525	19,000	16,900	0.56	0.78	5.72	8.53	8.20	23.40	24.60	6.35	3.31	10.24	50031074
08 B-2	D 85 ML-2	1/2	12.70	40,000	31,100	1.00	1.35	7.75	11.30	12.20	30.80	32.40	8.51	4.45	13.92	50030465
10 B-2	D 106 ML-2	5/8	15.875	49,000	44,500	1.34	1.85	9.65	13.28	14.40	36.00	37.50	10.16	5.08	16.59	50030466
12 B-2	D 127 ML-2	3/4	19.05	61,000	57,800	1.78	2.50	11.75	15.62	16.40	42.10	43.00	12.07	5.72	19.46	50030467
Triplex – ML-2 Roller Chains on request																
Simplex – ANSI Roller Chains, complying with ISO 606, American Standard																
08 A-1 ANSI 40	L 85 AML-2	1/2	12.70	17,500	13,900	0.44	0.60	7.94	11.15	12.00	16.60	17.50	7.95	3.96	-	50033770
12 A-1 ANSI 60	M 128 AML-2	3/4	19.05	41,000	31,300	1.06	1.47	12.70	17.75	18.00	25.30	26.70	11.91	5.96	-	50031073
16 A-1 ANSI 80	M 1610 AML-2	1	25.40	68,000	55,600	1.79	2.57	15.88	22.40	22.80	32.00	33.90	15.88	7.94	-	50032667

ML-2 Conveyor Chains on request

¹⁾ Differing dimensions for cranked links. If cranked links are fitted, it should be noted that the breaking strength of the chain may be reduced by approximately 20%. * straight side plates

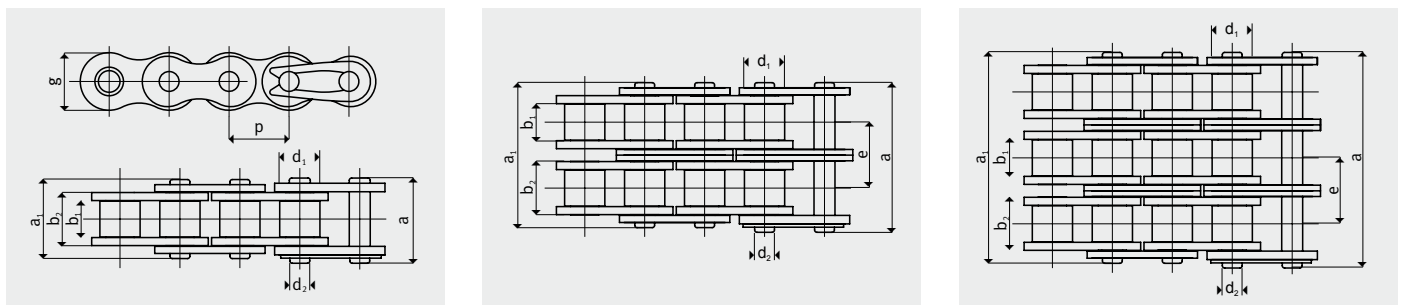

INDIVIDUAL COMPONENTS AND CONNECTING LINKS



Standard designation B
Inner link

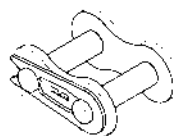

Standard designation E
Connecting link with spring clip

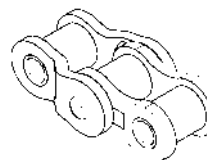

Standard designation C
Double cranked link

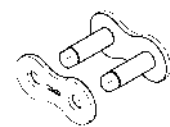

Standard designation A
Outer link



iwis® MEGAlife Conveyor Chains

Examples of special chain designs

MEGAlife Conveyor Chain with straight attachment plates

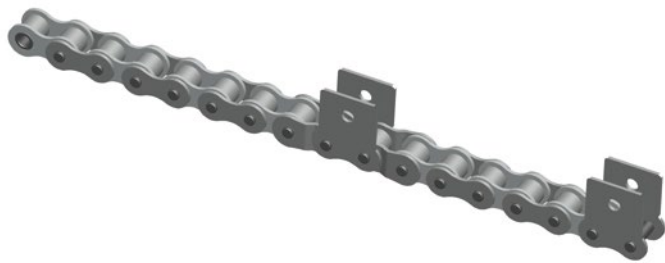

MEGAlife Conveyor Chain with extendend pins

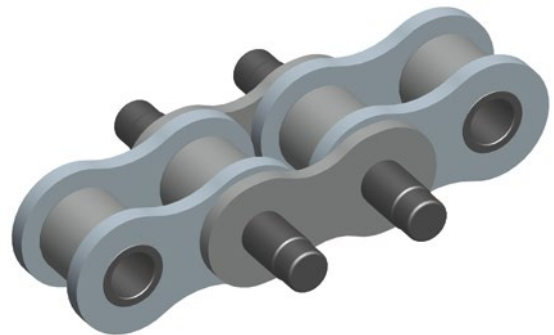

MEGAlife Conveyor Chain with bent attachment plates

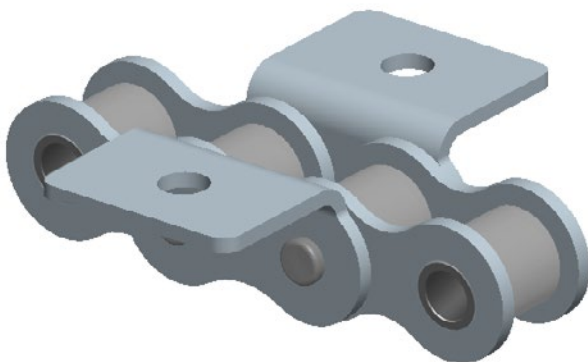

MEGAlife Conveyor Chain with special attachment plates

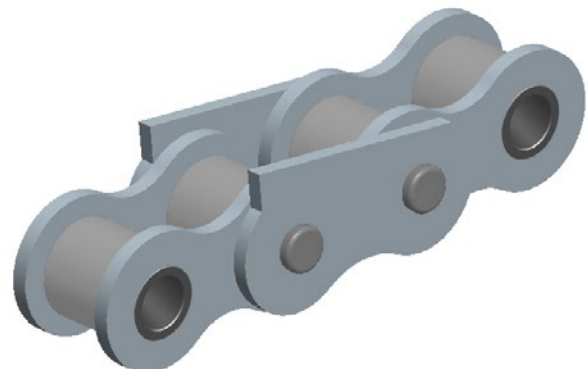



iwis Customer Service

CallBack Tel: +49 89 76909-1600 Fax: -1198

sales-muenchen@iwis.com

iwis® MEGAlife Maintenance-Free Accumulation Chains

More efficiency and sustainability

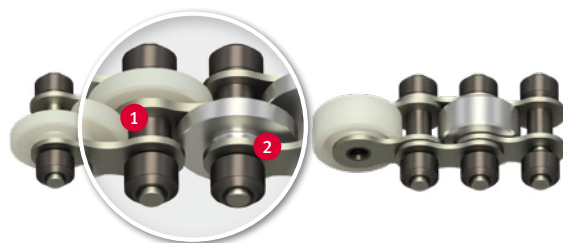

PROBLEM/INITIAL SITUATION

- Lubrication is not at all or only partly possible
- Clean and dry surroundings required
- Difficult/obstructed lubrication passage
- Contamination of installation and material to be conveyed due to chain lubrication

OUR SOLUTION

iwis accumulation chains with nickel-plated plates and pins, low-friction sintered metal rollers and a special bearing design – a technical innovation. **The first genuinely maintenance accumulation chains with low-friction rollers on the market.**

Types:

- VR: with offset transport rollers
- OS: standard version without washers
- M: standard version with washers

HIGHLIGHTS

- 1 **Special bearing design with sintered metal bushes**
- 2 Nickel-plated plates and pins, with eco-friendly, **lubricant-free surfaces** ensure reduced maintenance costs and less downtime for your application.

HIGHLIGHTS

- Excellent wear resistance – also under extreme environmental conditions
- Easy to dismantle
- Environmentally-friendly due to lubrication free chain surface
- Chains suitable for clean rooms

TECHNICAL FEATURES

- Dry chain surface and transport rollers
- Corrosion resistant
- Transport rollers optional as **plastic material or steel (stainless steel or nickel-plated)**
- Temperature range for use –40 °C up to +150 °C (for transport rollers made of steel)
- iwis MEGAlife accumulation chains are available in the new iwis or classic design in 1/2" and 3/4" pitch
- Transport rollers made of sintered metal reduce friction. This leads to reduction of driving power and strain on the chain.

AREAS OF APPLICATION

- Electronic industry and circuit board manufacture
- Packaging and food industry
- Conveyor-equipment
- Wood, glass and ceramic industry
- Medical technology

... and of course in all areas where relubrication is not at all or only partly possible.



EFFICIENT

Comparison of frictional force

Chain with iwis low-friction rollers

Chain with classic idler rollers



LONG SERVICE LIFE

Service life comparison (accumulation chains without relubrication)

iwis MEGAlife maintenance-free accumulation chains

Std. competitor chains



ECONOMICAL

Comparison of friction coefficient

iwis MEGAlife chains

Standard competitor chains

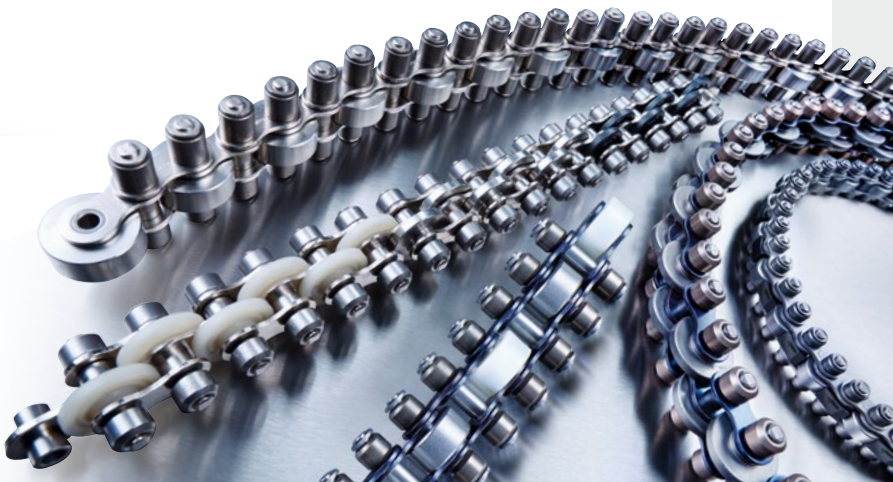

30% more efficient with iwis low-friction rollers



MEGALife Accumulation Chains

Range of products

iwis reference	Pitch p (mm)	Chain width B (mm)	b (mm)	b ₄ (mm)	e (mm)	Diameter Transport rollers (mm)	Loading capacity per roller (kg)	Weight (kg/m)
Design VR: Version with offset transport rollers*								
L 88 SFK-ML	12.70	27	9.2	14.50	18.70	16.00	6	0.85
L 88 SFS-ML	12.70	27	9.2	14.50	18.70	16.00	8	1.40
M 120 SFK-ML	19.05	40	11.70	19.55	29.0	24.0 / 26.0 / 27.0 / 28.0	10	1.8
M 120 SFK-ML	19.05	45	11.70	19.55	31.5	24.0 / 26.0 / 27.0 / 28.0	10	1.8
M 120 SFS-ML	19.05	40	11.70	19.55	29.0	24.0 / 26.0 / 27.0 / 28.0	15	2.8
M 120 SFS-ML	19.05	45	11.70	19.55	31.5	24.0 / 26.0 / 27.0 / 28.0	15	2.8

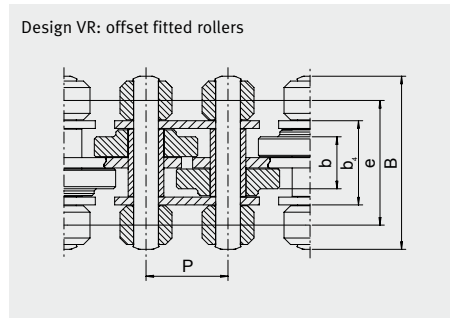

* Also available with optional V2A accumulation rollers

SFK – with plastic conveyor rollers
SFS – with hardened steel conveyor rollers

iwis reference	Pitch p (mm)	Chain width B (mm)	e (mm)	b ₁ (mm)	b ₂ (mm) max.	b ₃ (mm) max.	Width b (mm)	Diameter Transport rollers (mm)	Loading capacity per roller (kg)	Diameter Roller d ₁ (mm)	Diameter Pin d ₂ (mm)	Weight (kg/m)
Design OS: Standard version without washers												
L 85 SFK-ML	12.7	27	18.7	7.75	11.3	14.5	7.5	16.0	17.0	18.0	6	1.2
L 85 SFS-ML	12.7	27	18.7	7.75	11.3	14.5	7.5	16.0	17.0	-	8	1.8
M 127 SFK-ML	19.05	40	27.5	11.75	15.62	19.55	11.0	24.0	26.0	28.0	10	2.3
M 127 SFS-ML	19.05	40	27.5	11.75	15.62	19.55	11.0	24.0	26.0	28.0	15	3.1
Design M: Standard version with side-mounted washers												
M 127 SFK-ML	19.05	40	27.5	11.75	15.62	19.55	11.0	24.0	26.0	28.0	10	2.3
M 127 SFK-ML	19.05	43	29.0	11.75	15.62	19.55	11.0	24.0	26.0	28.0	10	2.3
M 127 SFK-ML	19.05	48	31.5	11.75	15.62	19.55	11.0	24.0	26.0	28.0	10	2.3
M 127 SFS-ML	19.05	40	27.5	11.75	15.62	19.55	11.0	24.0	26.0	28.0	15	3.1
M 127 SFS-ML	19.05	43	29.0	11.75	15.62	19.55	11.0	24.0	26.0	28.0	15	3.1
M 127 SFS-ML	19.05	48	31.5	11.75	15.62	19.55	11.0	24.0	26.0	28.0	15	3.1

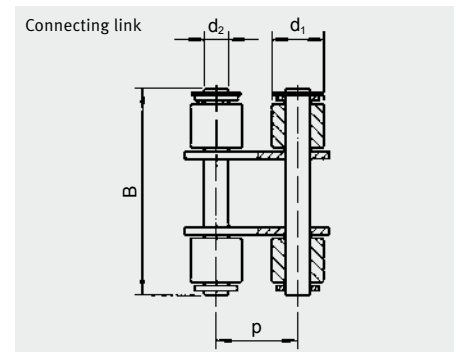
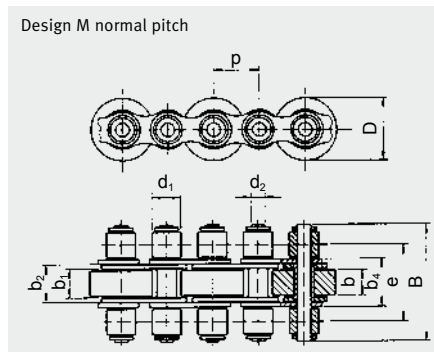
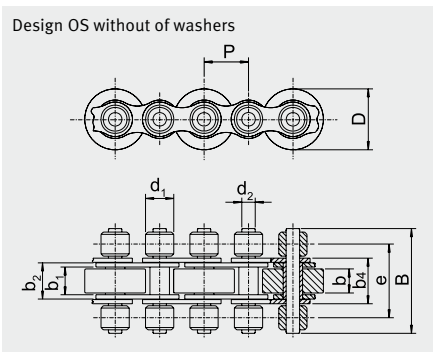



iwis® MEGAlife Roller and Conveyor Chains

Summary of benefits

MORE RELIABILITY



MEGAlife maintenance-free roller and conveyor chains offer a significantly longer service life than conventional low-maintenance/lube-free roller chains.

The benefits for you:

- Less downtime
- Longer replacement intervals for machine and system components
- Significant reduction of maintenance costs

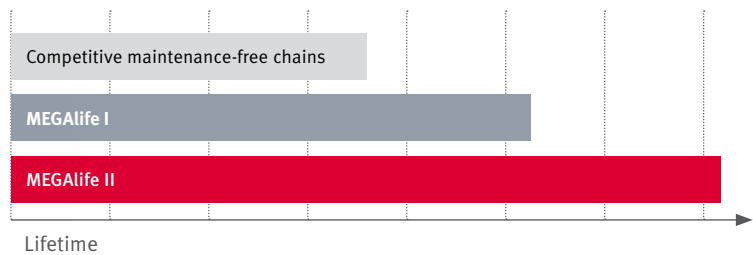

Trouble-free conversion of standard chains and conveyor chains to MEGAlife: **no additional adjustments or modifications required!**

MORE SUSTAINABILITY

MEGAlife = lubricant-free

MEGAlife maintenance-free roller chains and conveyor chains require no lubrication, so they are clean, dry and **environment-friendly**.

The benefits for you:

- Built-in relubrication units in machines and systems are no longer required.
- Lower energy costs, lower investments
- Conservation of fossil resources

iwis' own contribution for the environment!



iwis has been awarded the **ISO 14001:2004** (Environmental Management System) certificate by the Technical Inspection Association TÜV SÜD for its achievements in the field of "Development, manufacture and distribution of drive chains and conveyor chains".

