

C196 UPDATE



SOLID CONTROL HANDWHEEL

Material:

Reinforced and stabilised polyamide.
Oils and greases resistant.

Surface:

Satin.

Colour:

Black (RAL 9011).

Central Cap:

Grey polyamide (RAL 7035 cod. 13).

Alternative Cap Colour:

Orange (RAL 2004 cod. 02)
Blue (RAL 5015 cod. 07)
Yellow (RAL 1021 cod. 10)
Red (RAL 3000 cod. 16)
Green (RAL 6024 cod. 17)
Black (RAL 9011 cod. 01)

Main Insert:

Zinc plated steel insert with smooth through-hole (H10 tolerance).

For fixing system, or execution of keyway or square holes, please refer to the technical notes attached to the catalogue.

SPECIAL REQUEST:

- It's possible to supply the inserts with d1 bore by customer design, on request and for quantities.
- It's possible to supply the inserts in different material and treatment-finishes, on request and for quantities.
- It's possible to supply the products with colours (reduced range) as shown in the table at page C-11, on request and for quantities.

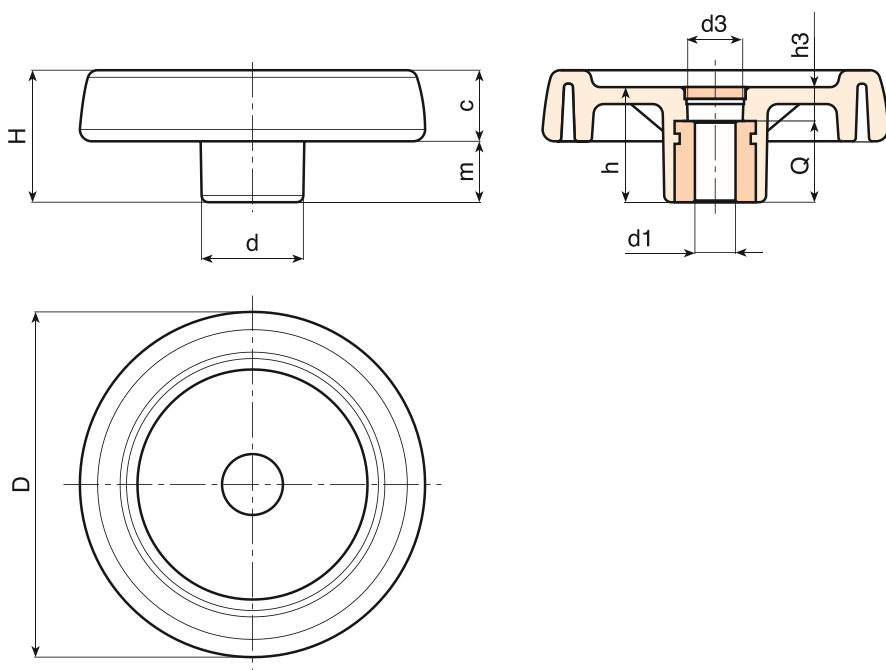

Version with zinc plated insert and H10 tolerance bore

Art.	D	H	h	d	m	c	d3	h3	Dm	d1 H10	Q	g
● C196080.TP0501P	81	33	29	25	16	17	16	9	12	05	20	100
● C196080.TD0801P	81	33	29	25	16	17	16	9	12	08	20	99
● C196080.TD1001P	81	33	29	25	16	17	16	9	12	10	20	99
● C196080.TD1201P	81	33	29	25	16	17	16	9	12	12	20	98
● C196100.TP0501P	100	39	34	30	18,5	20,5	16	10	16	05	24	192
● C196125.TP0501P	125	44	37	36	20	24	26	13	18	05	24	295
● C196125.TD1201P	125	44	37	36	20	24	26	13	18	12	24	290
● C196150.TD0801P	150	54	44	38	25	29	26	12	22	08	32	520
● C196150.TD1401P	150	54	44	38	25	29	26	12	22	14	32	515
● C196175.TD0801P	173	57	47	40	25,5	31,5	26	15	22	08	32	660
● C196200.TD0801P	202	59	49	44	24	35	27	13	28	08	36	870
● C196250.TD0801P	249	68	58	59	29	39	36	22	28	08	36	1420

Attention: bore d1 (H10 tolerance) could be produced by request, with 50 pieces minimum.

Dm = It's possible to increase the hole, by boring, until Dm (enlarge).