

BIPOLÁRIS LÉPTETŐ MOTOROK BIPOLAR STEPPER MOTORS

NEMA 17 (0,18Nm) TÍPUS
NEMA 17 (0,18Nm) TYPE

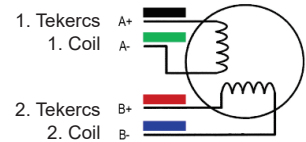
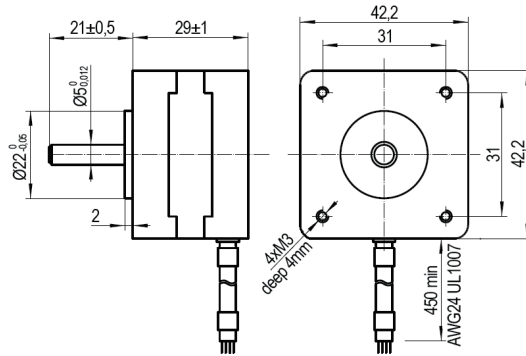
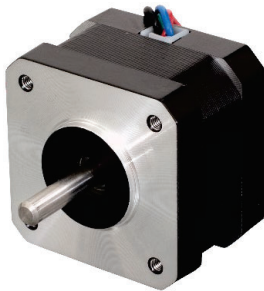

A motor és vezérlő bekötése
Connecting the motor and driver

Cikkszám Code	Kompatibilis meghajtó cikkszám Compatible driver code	Nyomaték Torque (Nm)	Fázis Phase	Fázis áram Phase current	Lépészőg Step angle	Feszültség Voltage	Fázis ellenállás Phase resistor	Fázis indukció Phase induction	Rotor inercia Rotor inertia	Tömeg Weight
				(A)	(°)	(V)	(Ω)	mH	(gcm ²)	(kg)
93.034.001	93.034.029	0,18	2	0,8	1,8	2,32	2,9 ± 10%	3 ± 20%	40	0,25

NEMA 17 (0,44Nm) TÍPUS
NEMA 17 (0,44Nm) TYPE

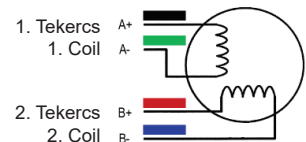
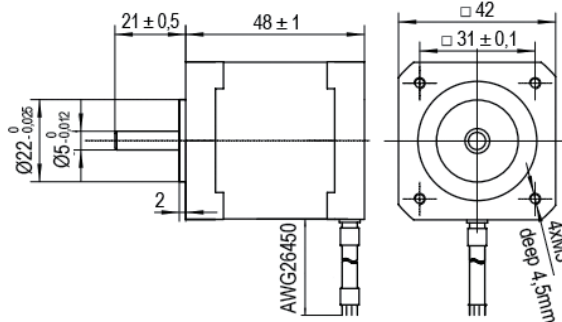
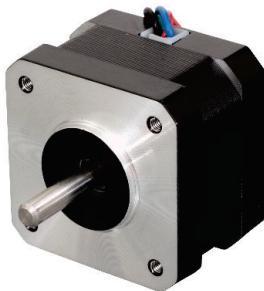

A motor és vezérlő bekötése
Connecting the motor and driver

Motor cikkszám Motor code	Kompatibilis meghajtó cikkszám Compatible driver code	Nyomaték Torque (Nm)	Fázis Phase	Fázis áram Phase current	Lépészőg Step angle	Feszültség Voltage	Fázis ellenállás Phase resistor	Fázis indukció Phase induction	Rotor inercia Rotor inertia	Tömeg Weight
				(A)	(°)	(V)	(Ω)	mH	(gcm ²)	(kg)
93.034.003	93.034.029	0,44	2	1,68	0,9	2,8	1,65	4,1	68	0,38



NEMA 17 (0,5Nm) TÍPUS NEMA 17 (0,5Nm) TYPE

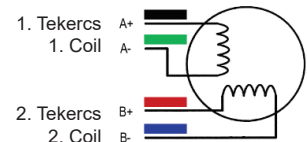
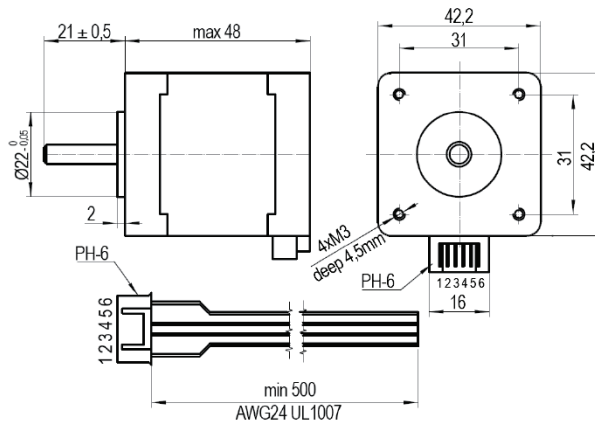
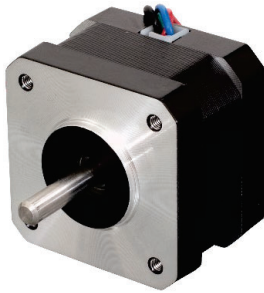

A motor és vezérlő bekötése
Connecting the motor and driver

Motor cikkszám Motor code	Kompatibilis meghajtó cikkszám Compatible driver code		Nyomaték Torque (Nm)	Fázis Phase	Fázis áram Phase current	Lépészög Step angle (°)	Feszültség Voltage (V)	Fázis ellenállás Phase resistor	Fázis indukció Phase induction	Rotor inercia Rotor inertia (gcm ²)	Tömeg Weight (kg)
	analóg	digitális			(A)			(Ω)	mH		
93.034.002	93.034.029		0,5	2	1,68	1,8	3,36	2 ± 10%	3,8 ± 20%	68	0,35

NEMA 23 (1Nm) TÍPUS NEMA 23 (1Nm) TYPE

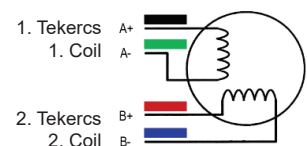
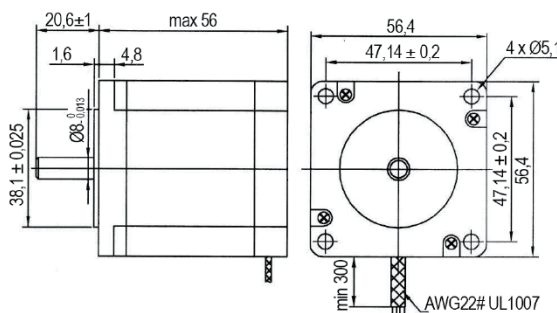

A motor és vezérlő bekötése
Connecting the motor and driver

Motor cikkszám Motor code	Kompatibilis meghajtó cikkszám Compatible driver code		Nyomaték Torque (Nm)	Fázis Phase	Fázis áram Phase current	Lépészög Step angle (°)	Feszültség Voltage (V)	Fázis ellenállás Phase resistor	Fázis indukció Phase induction	Rotor inercia Rotor inertia (gcm ²)	Tömeg Weight (kg)
	analóg	digitális			(A)			(Ω)	mH		
93.034.004	93.034.029	93.034.030	1	2	3	0,9	2,7	0,9	3,5	300	0,7

NEMA 23 (1,2Nm) TÍPUS NEMA 23 (1,2Nm) TYPE

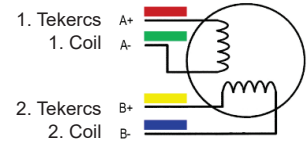
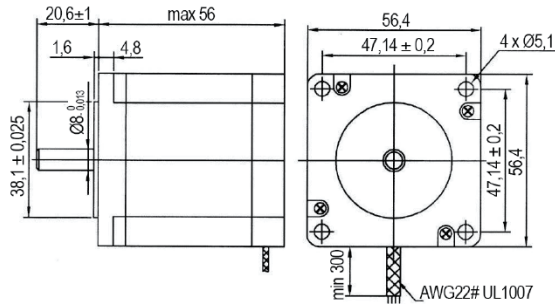
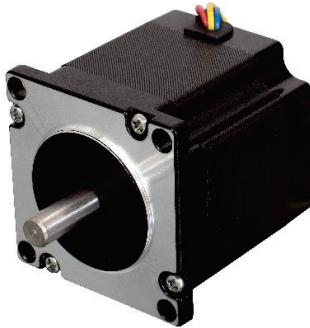

A motor és vezérlő bekötése
Connecting the motor and driver

Motor cikkszám Motor code	Kompatibilis meghajtó cikkszám Compatible driver code		Nyomaték Torque (Nm)	Fázis Phase	Fázis áram Phase current (A)	Lépészög Step angle (°)	Feszültség Voltage (V)	Fázis ellenállás Phase resistor (Ω)	Fázis indukció Phase induction mH	Rotor inercia Rotor inertia (gcm ²)	Tömeg Weight (kg)
	analog	digitális digital									
93.034.005	93.034.029	93.034.030	1,2	2	3	1,8	2,7	0,9	2,5	300	0,7

NEMA 23 (1,8Nm) TÍPUS NEMA 23 (1,8Nm) TYPE

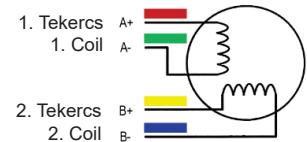
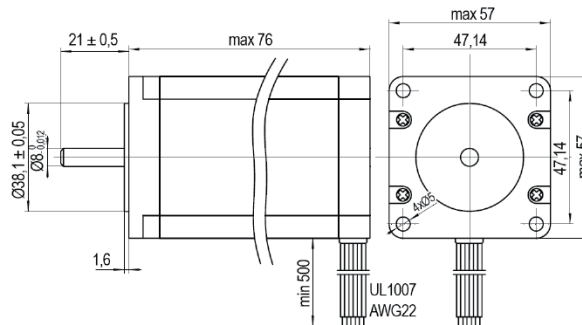
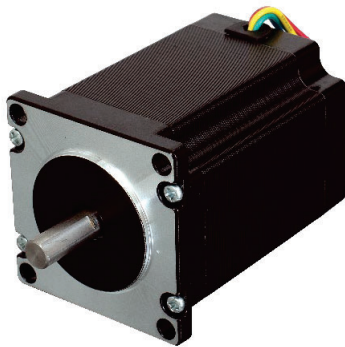

A motor és vezérlő bekötése
Connecting the motor and driver

Motor cikkszám Motor code	Kompatibilis meghajtó cikkszám Compatible driver code	Nyomaték Torque (Nm)	Fázis Phase	Fázis áram Phase current (A)	Lépészög Step angle (°)	Feszültség Voltage (V)	Fázis ellenállás Phase resistor (Ω)	Fázis indukció Phase induction mH	Rotor inercia Rotor inertia (gcm ²)	Tömeg Weight (kg)

NEMA 23 (1,9Nm) TÍPUS NEMA 23 (1,9Nm) TYPE

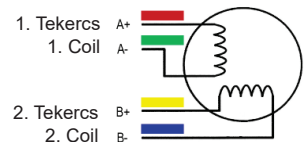
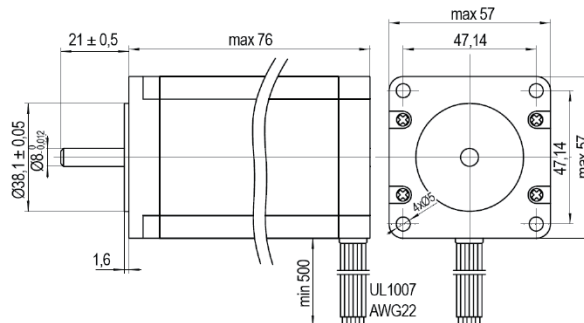
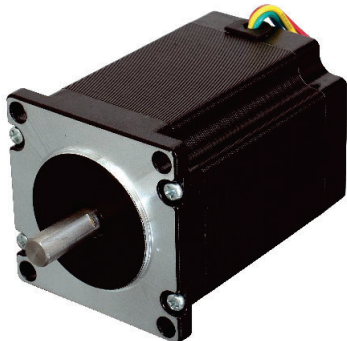

A motor és vezérlő bekötése
Connecting the motor and driver

Motor cikkszám Motor code	Kompatibilis meghajtó cikkszám Compatible driver code		Nyomaték Torque (Nm)	Fázis Phase	Fázis áram Phase current	Lépészög Step angle	Feszültség Voltage	Fázis ellenállás Phase resistor	Fázis indukció Phase induction	Rotor inercia Rotor inertia	Tömeg Weight
	analóg analog	digitális digital			(A)	(°)	(V)	(Ω)	mH	(gcm ²)	(kg)
93.034.008	93.034.029	93.034.030	1,9	2	2,8	1,8	3	1,1	3,6	480	1

NEMA 24 (2Nm) TÍPUS NEMA 24 (2Nm) TYPE

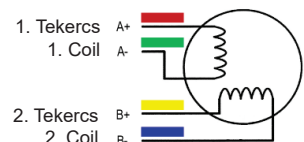
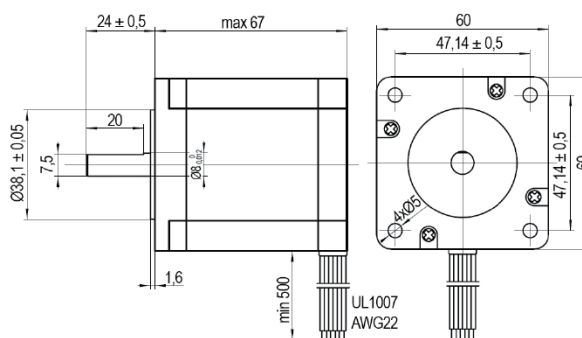
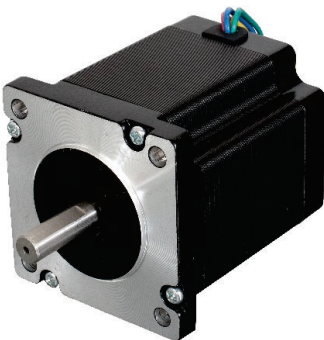

A motor és vezérlő bekötése
Connecting the motor and driver

Motor cikkszám Motor code	Kompatibilis meghajtó cikkszám Compatible driver code		Nyomaték Torque (Nm)	Fázis Phase	Fázis áram Phase current	Lépészög Step angle	Feszültség Voltage	Fázis ellenállás Phase resistor	Fázis indukció Phase induction	Rotor inercia Rotor inertia	Tömeg Weight
	analóg analog	digitális digital			(A)	(°)	(V)	(Ω)	mH	(gcm ²)	(kg)
93.034.011	93.034.029	93.034.030	3	2	4	1,8	3,2	0,8	3,5	860	1,4

NEMA 24 (3Nm) TÍPUS NEMA 24 (3Nm) TYPE

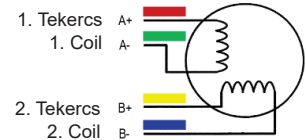
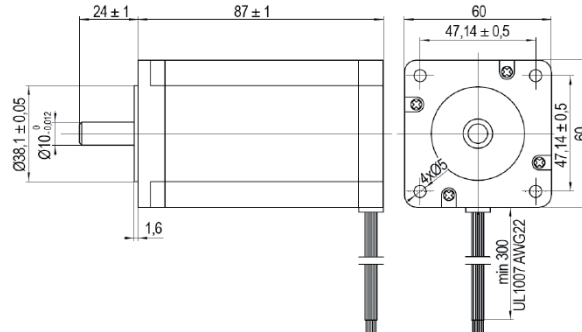

A motor és vezérlő bekötése
Connecting the motor and driver

Motor cikkszám Motor code	Kompatibilis meghajtó cikkszám Compatible driver code		Nyomaték Torque (Nm)	Fázis Phase	Fázis áram Phase current	Lépészőg Step angle	Feszültség Voltage	Fázis ellenállás Phase resistor	Fázis indukció Phase induction	Rotor inercia Rotor inertia	Tömeg Weight
	analóg analog	digitális digital			(A)	(°)	(V)	(Ω)	mH	(gcm ²)	(kg)
93.034.011	93.034.029	93.034.030	3	2	4	1,8	3,2	0,8	3,5	860	1,4

NEMA 24 (4Nm) TÍPUS NEMA 24 (4Nm) TYPE

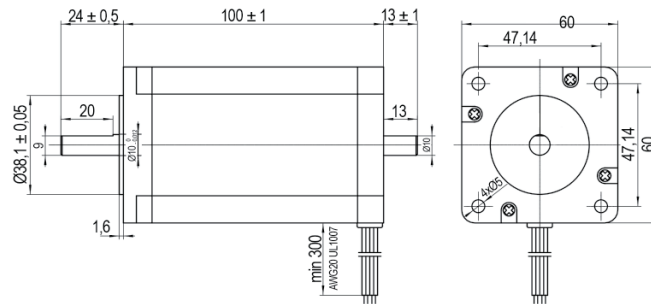
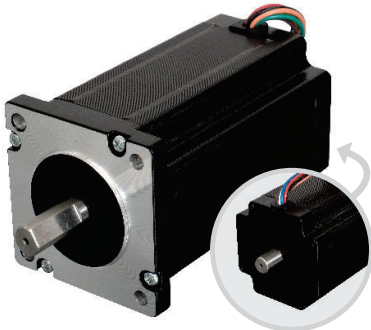

Motor cikkszám Motor code	Kompatibilis meghajtó cikkszám Compatible driver code		Bekötés Connecting	Nyomaték Torque (Nm)	Fázis Phase	Fázis áram Phase current	Lépészőg Step angle	Fázis ellenállás Phase resistor	Fázis indukció Phase induction	Rotor inercia Rotor inertia	Tömeg Weight
	analóg analog	digitális digital				(A)	(°)	(Ω)	mH	(gcm ²)	(kg)
93.034.012	93.034.029	93.034.030	Párhuzamos / Parallel	4	2	4	1,8	0,7	3	1200	1,6
			Soros / Serial	4		2		2,8	12		
			Unipoláris / Unipolar	2,8		2,8		1,4	3		

A. Bipoláris – soros / A. Bipolar - serial

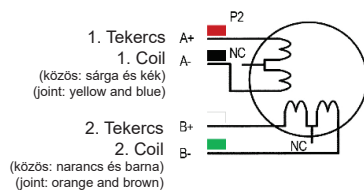

B. Bipoláris – párhuzamos / B. Bipolar - parallel

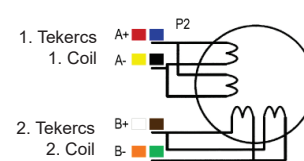

A motor és vezérlő bekötése / Connecting the motor and driver



NEMA 34 (3,2Nm) TÍPUS NEMA 34 (3,2Nm) TYPE

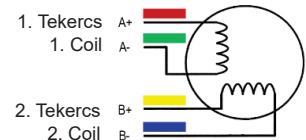
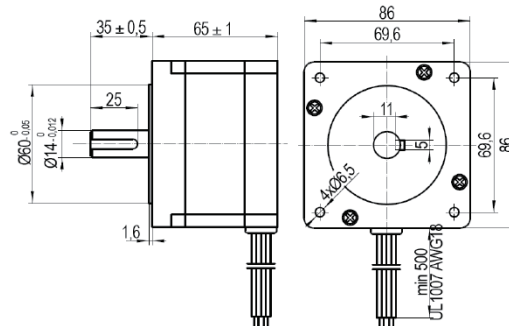

A motor és vezérlő bekötése
Connecting the motor and driver

Motor cikkszám Motor code	Kompatibilis meghajtó cikkszám Compatible driver code		Nyomaték Torque (Nm)	Fázis Phase	Fázis áram Phase current (A)	Lépészőg Step angle (°)	Fázis ellenállás Phase resistor (Ω)	Fázis indukció Phase induction mH	Rotor inercia Rotor inertia (gcm ²)	Tömeg Weight (kg)
	analóg analog	digitális digital								
93.034.013	93.034.029	93.034.030 93.034.031	3,2	2	4	1,8	0,7±10%	3,9±20%	1200	1,7

NEMA 34 (6,6Nm) TÍPUS NEMA 34 (6,6Nm) TYPE

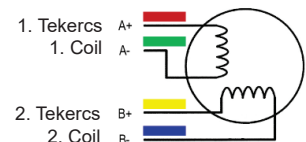
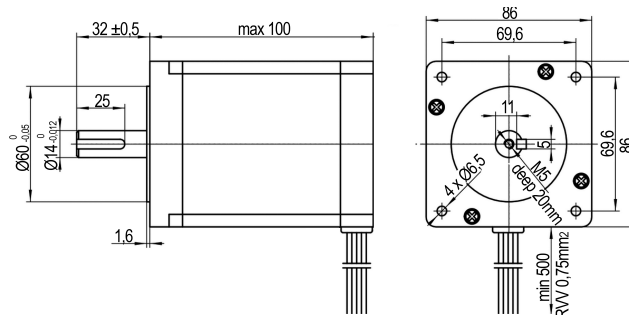
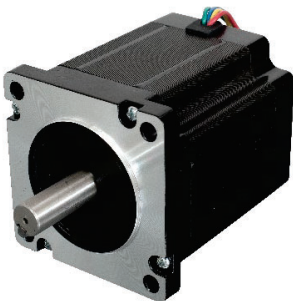

A motor és vezérlő bekötése
Connecting the motor and driver

Motor cikkszám Motor code	Kompatibilis meghajtó cikkszám Compatible driver code		Nyomaték Torque (Nm)	Fázis Phase	Fázis áram Phase current (A)	Lépészőg Step angle (°)	Fázis ellenállás Phase resistor (Ω)	Fázis indukció Phase induction mH	Rotor inercia Rotor inertia (gcm ²)	Tömeg Weight (kg)
	analóg analog	digitális digital								
93.034.014	93.034.029	93.034.030 93.034.031	6,6	2	5	1,8	0,5	4	2000	3,2

NEMA 34 (8,7Nm) TÍPUS NEMA 34 (8,7Nm) TYPE

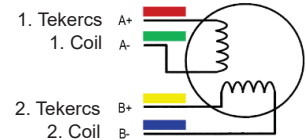
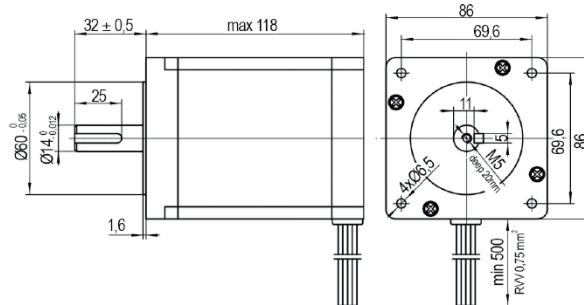
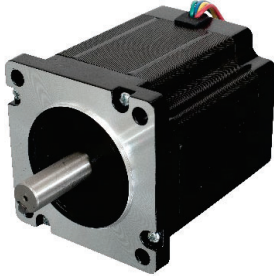

A motor és vezérlő bekötése
Connecting the motor and driver

Motor cikkszám Motor code	Kompatibilis meghajtó cikkszám Compatible driver code	Nyomaték Torque (Nm)	Fázis Phase	Fázis áram Phase current	Lépészög Step angle	Fázis ellenállás Phase resistor	Fázis indukció Phase induction	Rotor inercia Rotor inertia	Tömeg Weight
	digitális digital			(A)	(°)	(Ω)	mH	(gcm ²)	(kg)
93.034.015	93.034.031	8,7	2	6	1,8	0,6	6,5	2700	3,8

NEMA 34 (12Nm) TÍPUS NEMA 34 (12Nm) TYPE

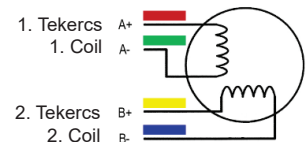
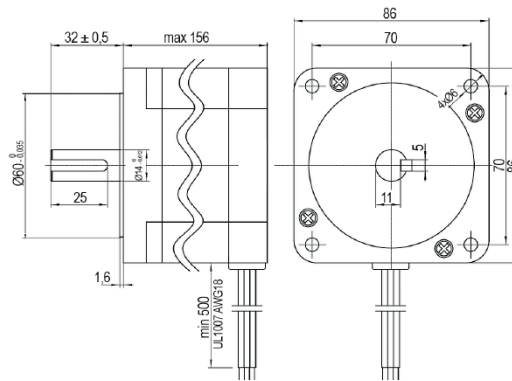
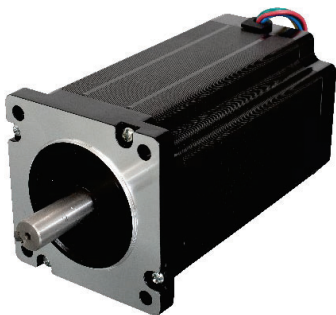

A motor és vezérlő bekötése
Connecting the motor and driver

Motor cikkszám Motor code	Kompatibilis meghajtó cikkszám Compatible driver code	Nyomaték Torque (Nm)	Fázis Phase	Fázis áram Phase current	Lépészög Step angle	Fázis ellenállás Phase resistor	Fázis indukció Phase induction	Rotor inercia Rotor inertia	Tömeg Weight
	digitális digital			(A)	(°)	(Ω)	mH	(gcm ²)	(kg)
93.034.016	93.034.031	12	2	6,2	1,8	0,75	9	4000	5,5
	93.034.032								



NEMA 43 (20Nm) TÍPUS NEMA 43 (20Nm) TYPE

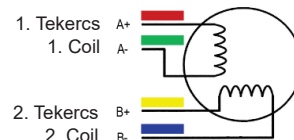
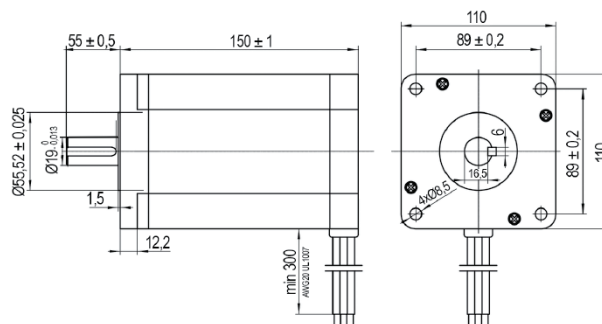
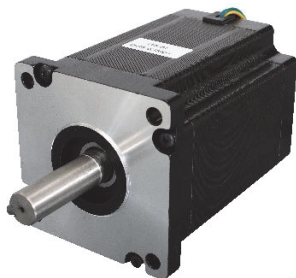

A motor és vezérlő bekötése
Connecting the motor and driver

Motor cikkszám Motor code	Kompatibilis meghajtó cikkszám Compatible driver code	Nyomaték Torque (Nm)	Fázis Phase	Fázis áram Phase current	Lépészőg Step angle	Fázis ellenállás Phase resistor	Fázis indukció Phase induction	Rotor inercia Rotor inertia	Tömeg Weight
	digitális digital			(A)	(°)	(Ω)	mH	(kgcm ²)	(kg)
93.034.017	93.034.031	20	2	6,5	1,8	0,72	12,8	210	8,4
	93.034.032								

NEMA 43 (33Nm) TÍPUS NEMA 43 (33Nm) TYPE

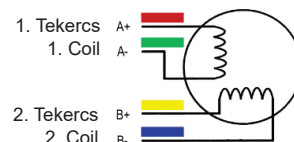
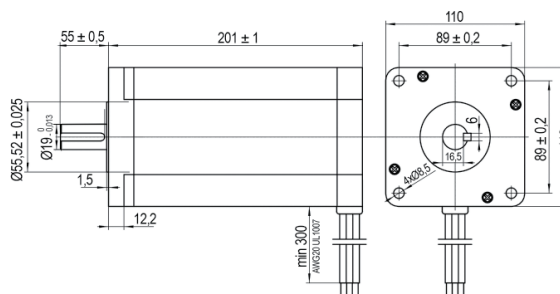
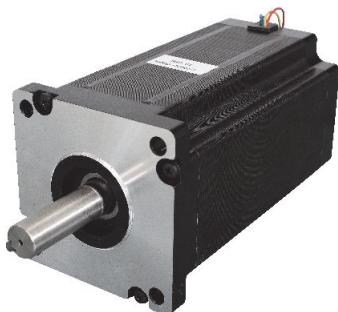

A motor és vezérlő bekötése
Connecting the motor and driver

Motor cikkszám Motor code	Kompatibilis meghajtó cikkszám Compatible driver code	Nyomaték Torque (Nm)	Fázis Phase	Fázis áram Phase current	Lépészőg Step angle	Fázis ellenállás Phase resistor	Fázis indukció Phase induction	Rotor inercia Rotor inertia	Tömeg Weight
	digitális digital			(A)	(°)	(Ω)	mH	(kgcm ²)	(kg)
93.034.018	93.034.031	33	2	8	1,8	0,71	15,38	330	11,7
	93.034.032								